

Electric Strikes

GK1900 Series

Preload Strikes for Sliding Door Applications



HK1900



GK1900



GK1900M



The GK1900 series electric strike is designed for use with hook bolt locks with a thumb turn or key cylinder. It has 100 lbs of preload release capability that allows smooth operation under door preload conditions. Suitable for sliding doors.

Standard Features

- Non-handed
- Fail-secure
- Zinc alloy body
- Easy-to-connect terminal block
- Optional latch / door status monitor

Specifications

- Operating voltage: 12/24 VDC
- Cavity Depth: 5/8" (15.5mm)
- Keeper width: 3/4" (19mm)
- Endurance: Over 250,000 cycles
- Static strength: 700 lbs
- Preload: Up to 100 lbs of preload



GK1900 Series Electric Strike & Compatible Locks

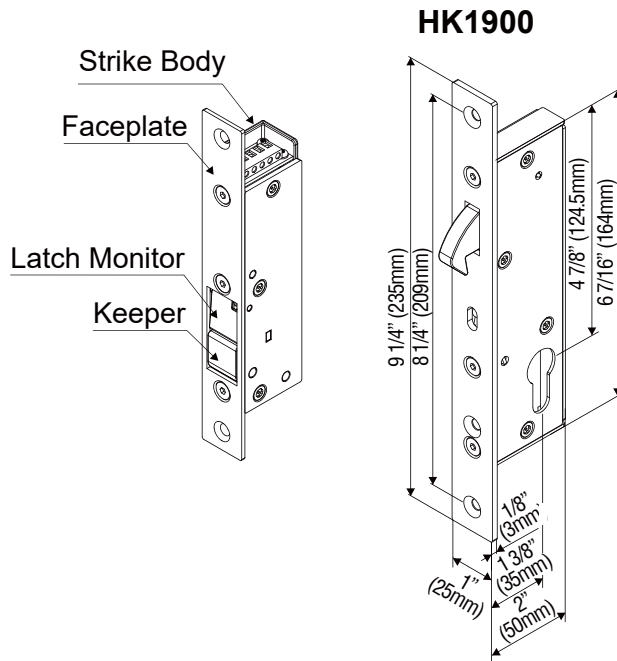

Dimensions

Hollow Metal Frame Installation

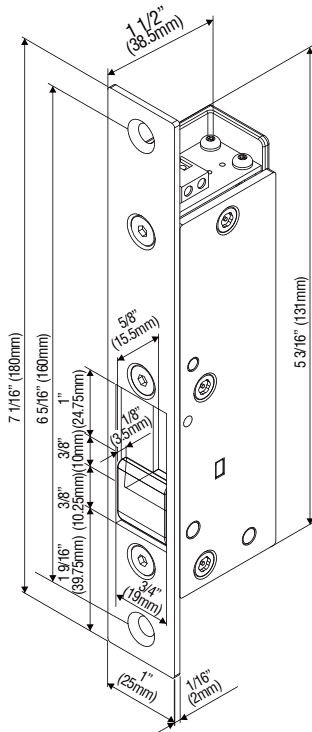

GK1900

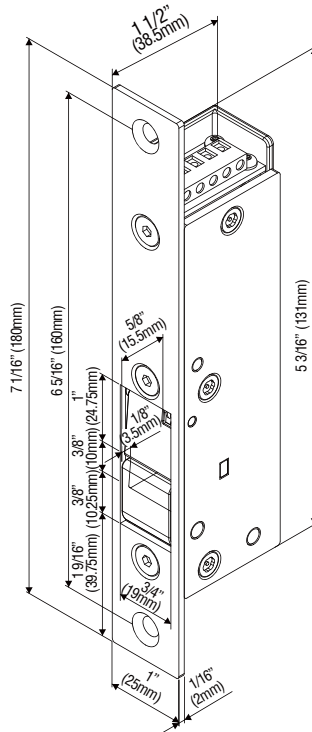

GK1900M
(Model with Latch Monitor)

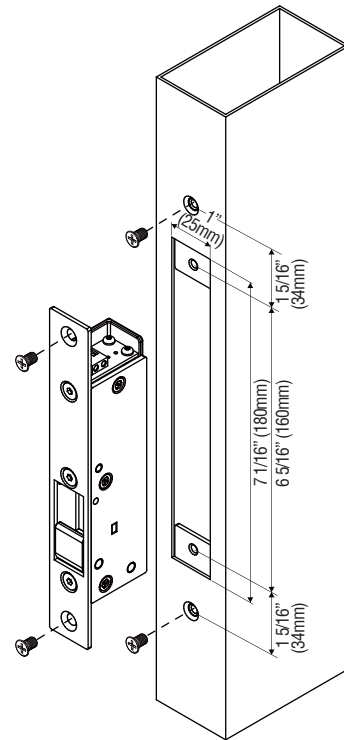

Unit: mm

Installation Diagram

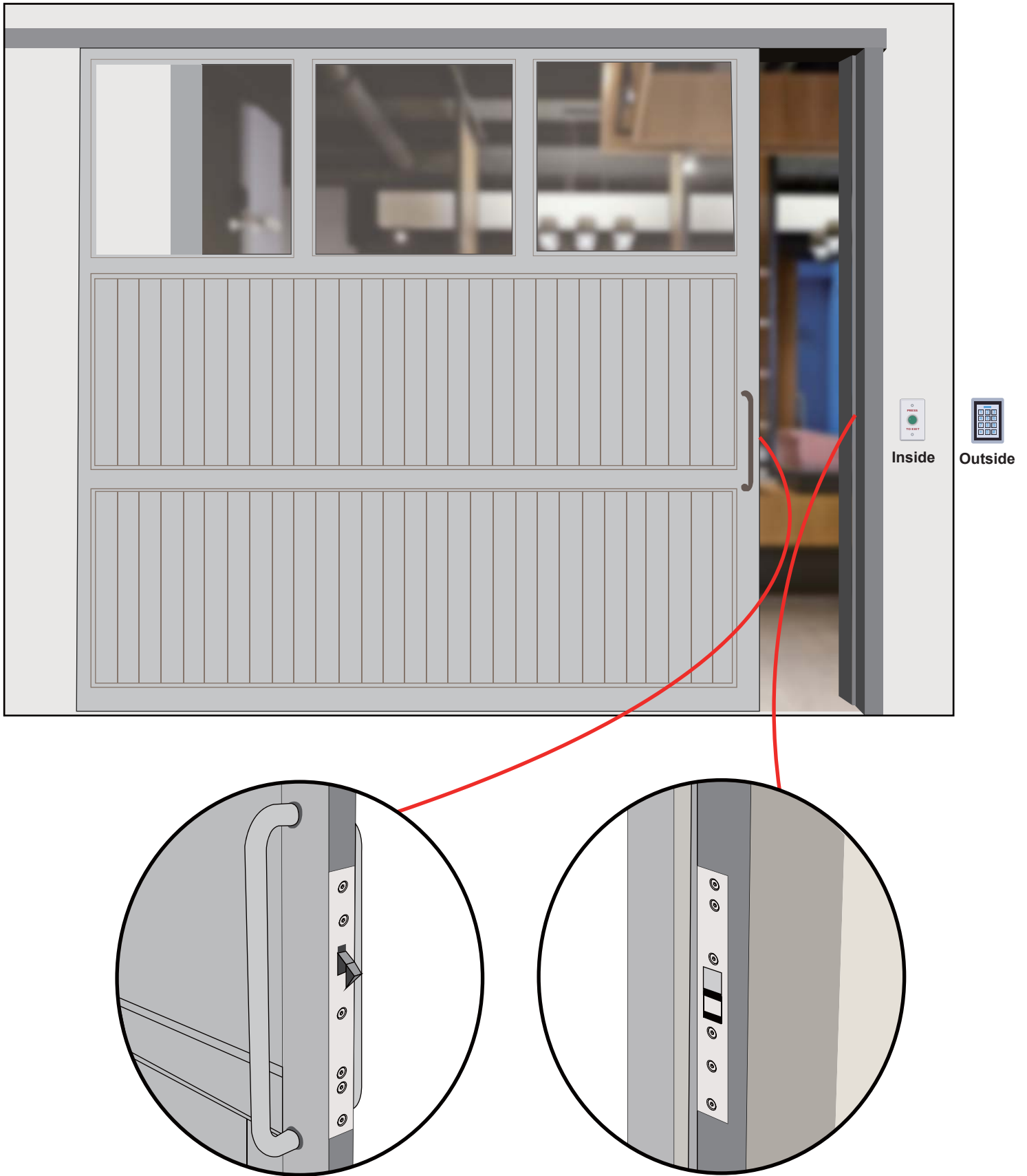

Warranty

The product is warranted against defects in material and workmanship while used in normal service for a period of 3 years from the date of sale to the original client. The GEM policy is one of continual development and improvement; therefore GEM reserves the right to change specifications without notice.